



***LifeSize[®] Focus[™]
Installation Guide***

August 2009

Copyright Notice

©2008-2009 LifeSize Communications Inc, and its licensors. All rights reserved.

LifeSize Communications has made every effort to ensure that the information contained in this document is accurate and reliable, but assumes no responsibility for errors or omissions. Information in this document is subject to change without notice. Companies, names, and data used in examples herein are fictitious unless noted. This document contains copyrighted and proprietary information, which is protected by United States copyright laws and international treaty provisions. No part of the document may be reproduced or transmitted, in any form or by any means, electronic or mechanical, for any purpose, without the express written permission from LifeSize Communications.

Trademark Acknowledgments

LifeSize® is the trademark of LifeSize Communications Inc. All other trademarks are the property of their respective owners.

Patent Notice

For patents covering LifeSize® products, refer to <http://www.lifesize.com/support/legal>.

Contacting Customer Support

If you have questions, concerns, or need assistance, contact your LifeSize Channel Partner.

Providing Customer Feedback

LifeSize Communications welcomes your comments regarding our products and services. If you have feedback about this or any LifeSize product, please send it to feedback@lifesize.com. Contact information for LifeSize Communications is as follows:

<i>Method</i>	<i>Address</i>
Internet	http://www.lifesize.com
E-mail	support@lifesize.com
Phone	(877) LIFESIZE or (877) 543-3749 (512) 347-9300
Fax	(512) 347-9301

Welcome to LifeSize Video Communications Systems

LifeSize high definition video communications systems enable anyone with dispersed colleagues and operations to collaborate more clearly and effectively. Each system is designed to make video communication a highly productive, simple, and reliable experience.

This guide explains how to install LifeSize Focus for use with a LifeSize video communications system. Related documentation is available from the documentation CD included in the product box and from the Support page of www.lifesize.com.

Installation Overview

LifeSize Focus is a fixed focus camera that includes microphones for audio input during calls. Installing LifeSize Focus includes the following tasks:

1. Attach the camera to a mount.
2. Remove the lens cap.
3. Connect the camera to the codec.
4. Adjust the camera position, if necessary.
5. Select the device you wish to use as the active microphone for audio input during calls.

Installation Prerequisites

Before installing LifeSize Focus, complete the following tasks:

- Ensure that your LifeSize video communications system is installed with software release v3.5 or later.
- Select a mounting option for the camera:
 - **desktop mount**—a movable mount for positioning the camera on a desk or table.
 - **display mount**—a fixed mount for positioning the camera on top of a display connected to your LifeSize video communications system. The mount attaches to the display with an adhesive tape located under the base of the mount. The adhesive requires 72 hours to achieve full bond strength at room temperature. Plan your installation to allow time for the adhesive to bond securely to the display.

The adhesive tape is intended for a single use and permanent application. LifeSize recommends that you determine the optimal area for placing the camera by removing the lens cap and connecting it to the codec as described in this document before attaching the mount to the display. For information about techniques that you may consider for removing the adhesive tape and cleaning the adhesive residue from the display surface, contact the 3M company to obtain product documentation for 3M VHB tapes. To obtain a replacement display mount, contact your LifeSize reseller.

WARNING: Use the desktop and display mounts on a horizontal surface only. Using either mount on a vertical surface or on a surface with a slope greater than 10 degrees may cause the camera to detach from the mount resulting in damage to the camera.

- **tripod socket**—a 1/4-20 UNC threaded socket for connecting the camera to a tripod. Refer to “Using the Tripod Socket” on page 8.
 - Note:** LifeSize Focus does not include a tripod.
- If you intend to use the camera as the active microphone for audio input during calls, follow these guidelines to optimize camera placement:
 - Avoid placing the camera less than .5 meters (1.64 feet) away from the front of the speakers connected to your LifeSize video communications system.
 - Avoid placing devices that generate noise (such as fans or personal computers) between video conference participants and the camera.
 - The camera microphones attenuate sound directed at the back of the camera. Place the camera in a location that ensures video conference participants speak in front of the camera from a distance greater than .5 meters but less than 2.5 meters (8.2 feet).

Installing LifeSize Focus

LifeSize Focus includes the following components:

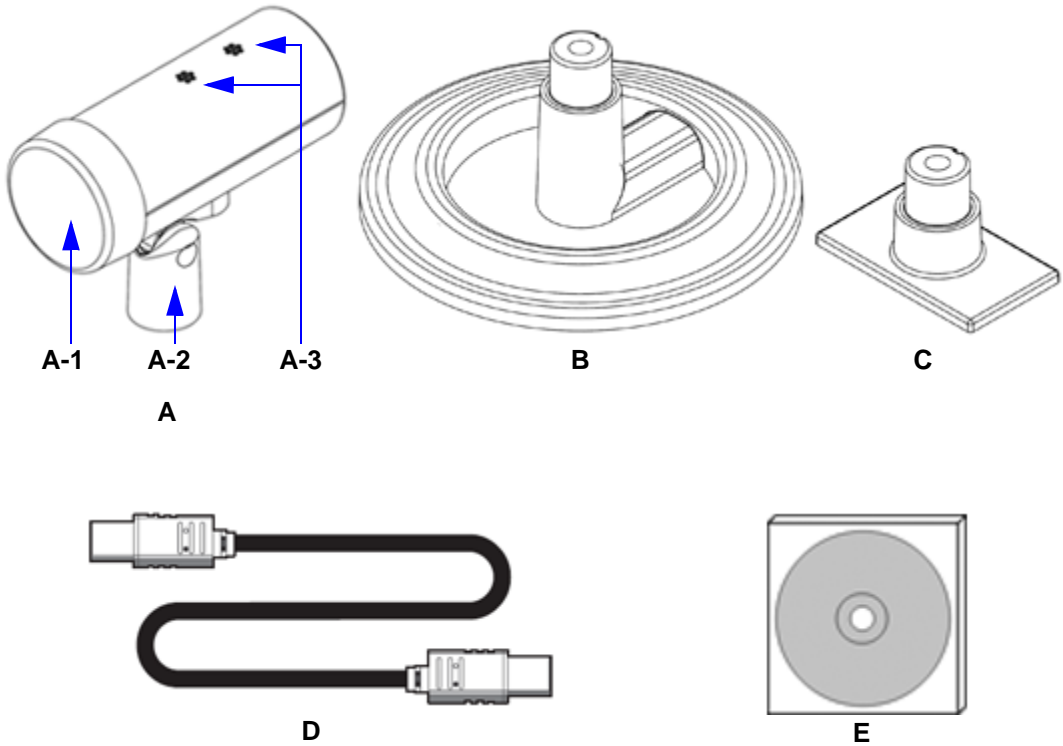

Component	Description
A	camera with lens cap (A-1), pivot collar (A-2), and microphones (A-3)
B	desktop mount
C	display mount
D	camera cable (3 meters)
E	documentation CD

1. Attaching the Camera to a Mount

Follow the instructions in this section to attach the camera to a mount.

Attaching the Desktop Mount

To attach the camera to the desktop mount, slide the pivot collar on the camera over the pivot on the mount.

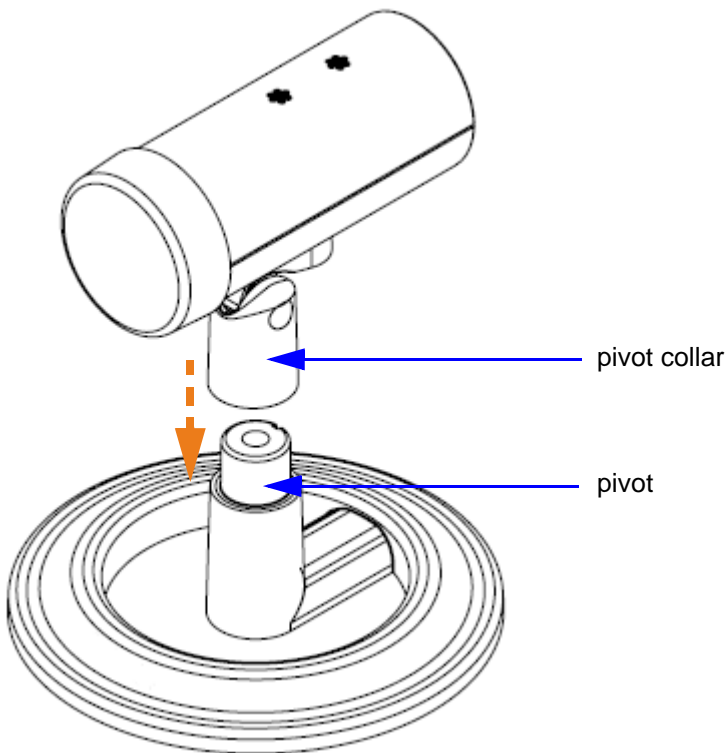

Attaching the Display Mount

To attach the camera to the display mount, follow these steps:

1. Ensure that the temperature in the room in which the display is located is at least 60°F (15°C). The ideal temperature range for applying the adhesive tape on the mount is 70°F to 100°F (21°C to 38°C).

WARNING: At temperatures below 60°F (15°C), the adhesive may fail to adhere readily to the display.

-
2. Ensure that the area on top of the display where you intend to attach the mount meets the following conditions:
 - horizontal
 - clean (free of dirt, dust, oil, and other residues)
 - dry and free of condensed moisture
 3. Remove the red film from the adhesive under the display mount.
 4. Press the mount firmly into place on top of the display.
 5. Allow the adhesive to bond to the display. At room temperature, the bond formed by the adhesive reaches full strength after 72 hours.

WARNING: Ensure that the mount is securely attached to the display before proceeding with the installation. An insecure mount can fail resulting in damage to the camera.
 6. Attach the camera to the display mount by sliding the pivot collar on the camera over the pivot on the mount.

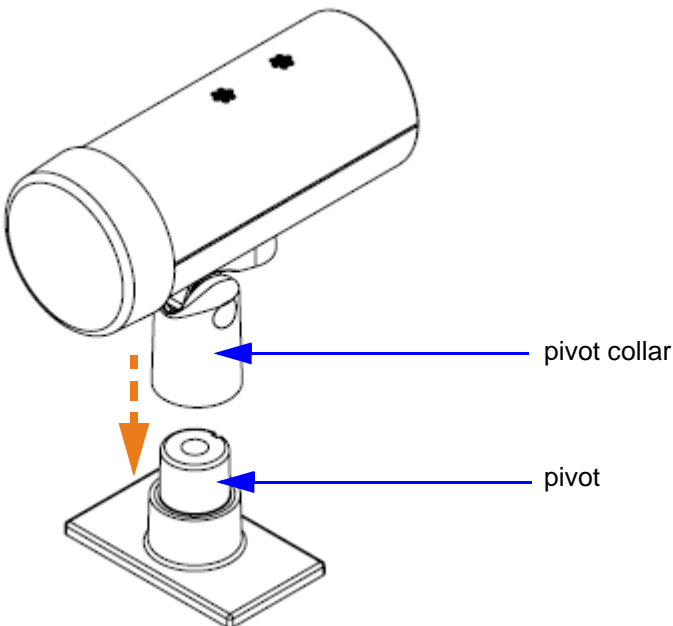

Using the Tripod Socket

The tripod socket and a screw secure the pivot collar to the camera. To expose the tripod socket for use with a tripod, loosen the screw until the pivot collar detaches from the camera.

Note: The screw remains attached to the pivot collar.

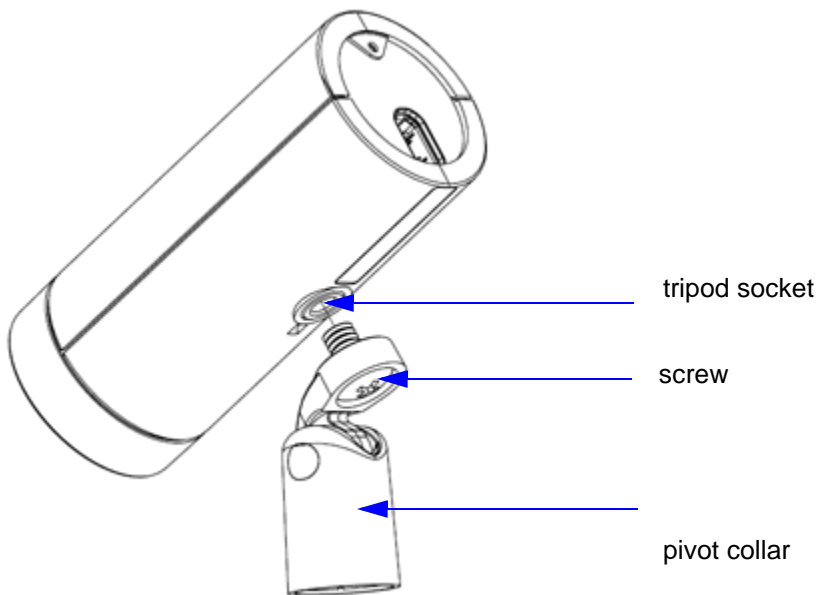

2. Removing the Lens Cap

Remove the lens cap from the camera.

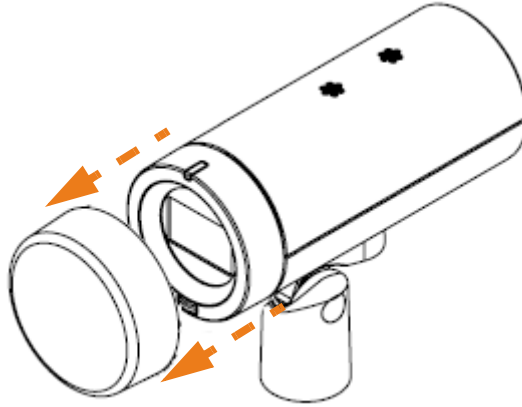

Removing the lens cap also exposes the status LED and the infrared (IR) sensor.

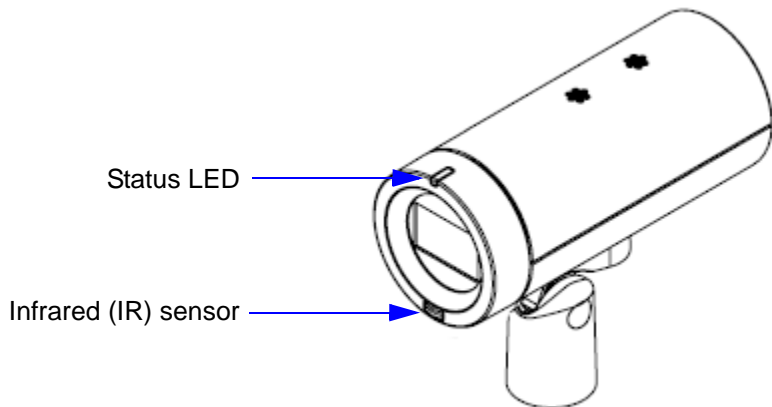

The IR sensor detects signals from the LifeSize remote control up to eight meters (26 feet) away when you use the remote control within two meters (6.5 feet) to the left or right of the front of LifeSize Focus. If you use the remote control directly in front of LifeSize Focus, the IR sensor detects the signal up to 14 meters (45 feet) away.

The status LED indicates the status of the camera as follows:

LED Color	Status
No color	Power is off.
Purple flash	The camera is initializing.
Blue flash	The camera software is upgrading.
Dim blue	The camera is receiving power and is inactive.
Bright blue	The camera is receiving power and is active.
Bright blue flash	Signal received from the LifeSize remote control.
Solid red or purple	The camera is malfunctioning. Contact LifeSize Technical Services for assistance.

3. Connecting the Camera to the Codec

To connect the camera to the LifeSize codec, insert one end of the camera cable into the port on the back of the camera and insert the opposite end into the port marked with the camera  symbol on the back panel of the codec.

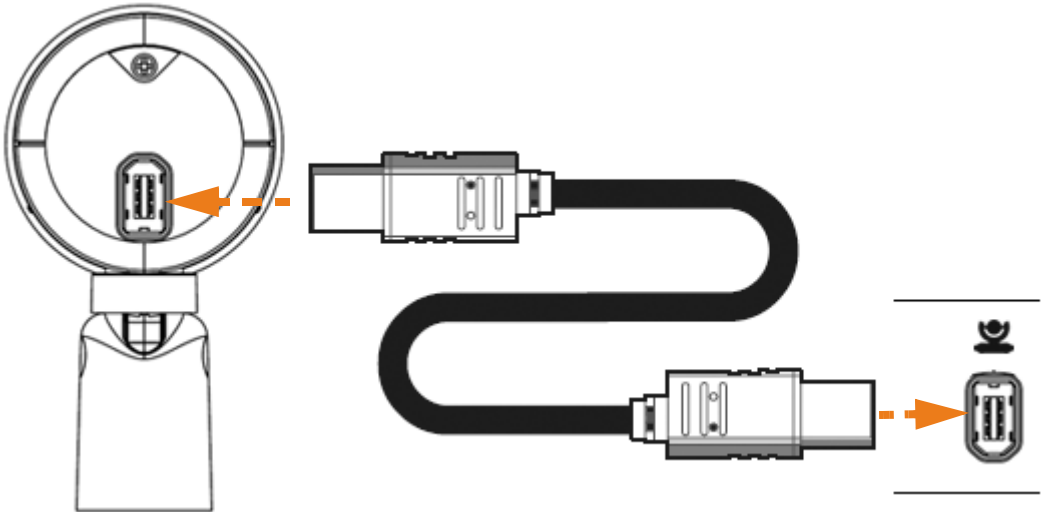

Note: Depending on the model of your LifeSize video communications system, the camera symbol appears either above or below the port on the codec.

4. Adjusting the Camera Position

Use the pivot collar to tilt and pivot the camera manually when using either the desktop or display mount. The pan, tilt, zoom, and camera preset buttons on the LifeSize remote control are not supported with this camera.

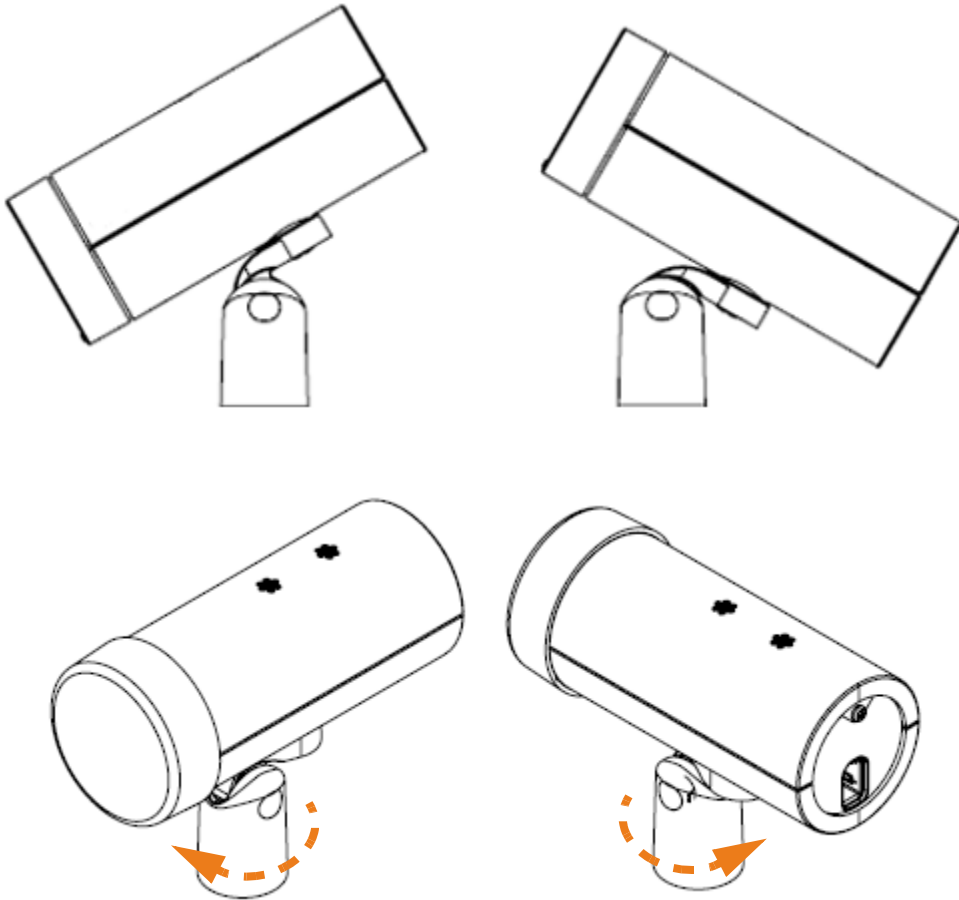

5. Controlling the Camera Microphones

You can use LifeSize Focus as both the video and audio input for your LifeSize video communications system. If you do not have a LifeSize Phone or LifeSize MicPod connected to your LifeSize video communications system in addition to LifeSize Focus, and you use the default system settings, the system uses LifeSize Focus as the active microphone.

If LifeSize Focus is one of several audio input devices connected to your system, and you want LifeSize Focus to be the active microphone, you must explicitly set the active microphone preference at **Administrator Preferences : Audio : Active Microphone**. For more information on selecting the active microphone, refer to the *LifeSize Video Communications Systems Administrator Guide*.

Navigate to the **System Information** page on your LifeSize system to verify which audio input device is the active microphone. When the active microphone status is *None*, the No Active Microphone  indicator appears in the status bar indicating that no active microphone is available.

To control the volume of the active microphone, adjust the **Active Microphone Volume** preference in **User Preferences** or **Administrator Preferences : Audio**.

To mute or unmute the camera microphones during a call, press the mute  button on the LifeSize remote control. A mute icon appears in the user interface. If a LifeSize Phone or LifeSize MicPod is connected to the system, you can also mute the microphones on the camera by pressing the mute button on either of these devices.

Troubleshooting

The following sections describe symptoms, possible causes, and potential solutions for common problems you may encounter when installing LifeSize LifeSize Focus.

No Video

If no video appears in the display from the camera:

- Ensure that the camera cable is securely connected to the camera and to the appropriate camera input on the codec and that nothing is obstructing the cable.
- Verify that the blue LED on the front of the camera is lit, indicating that the camera is receiving power. Reboot the LifeSize system if necessary to verify that the camera receives power.
- Navigate to the **System Information** page and locate the **HD Camera 1** (and **HD Camera 2** if you are using two cameras with LifeSize Room) and **Type** fields for the cameras. Ensure that the status of each connected camera is *Ready* and that *Fixed + Microphone* appears as the type for the LifeSize Focus connected to the system.

-
- Ensure that the primary input for your LifeSize system is set to the high definition camera.
 - Ensure that cable connections from the display to the codec are correct and secure and that the display is receiving power.

Distorted or Dark Video

If video appears blurred or dark:

- Ensure that the camera lens is clean. Use a dry, soft, lint-free cloth to clean the camera lens.
- Adjust the room lighting, or navigate to **User Preferences : Diagnostics : High Definition Camera** and adjust the **HD Camera Brightness** preference.

Distorted Audio Received at Far End

If you are using the camera as the active microphone for audio input during calls and far end participants report distorted audio, ensure that the camera is placed more than .5 meters away from the front of the speakers attached to the LifeSize system. Refer to “Installation Prerequisites” on page 4 for information about camera placement.